

### MOTOR VALVE FITTING INSTALLATION INSTRUCTIONS

ALL SERIES OF OUR PRESENT MOTOR VALVES HAVE AN ESTABLISHED ASSEMBLY STANDARD #40 WHICH SPECIFICALLY STATES THE RECOMMENDED TORQUE FOR PNEUMATIC LINE FITTINGS AND END PLATES SHOWN BELOW:

AIR PUSH II  
MOTOR VALVE

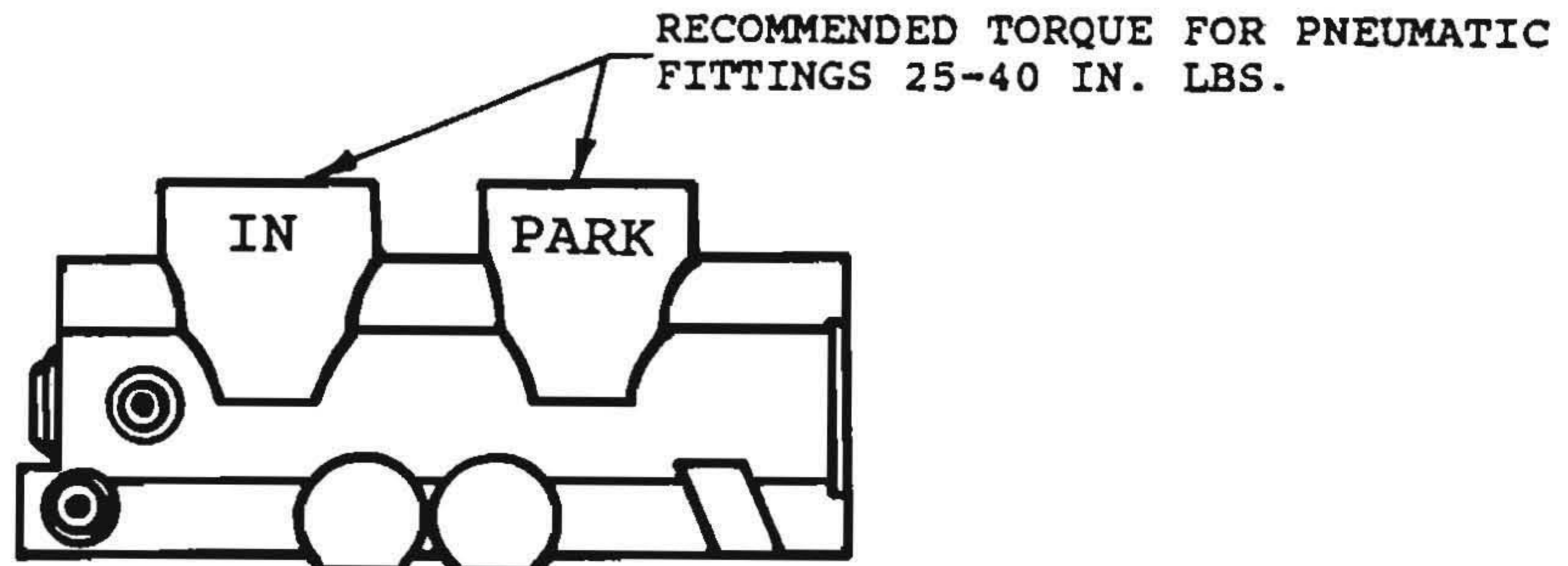

POWER PLUS SUPER  
CHALLENGER AND  
POWER PLUS  
CHALLENGER  
MOTOR VALVE

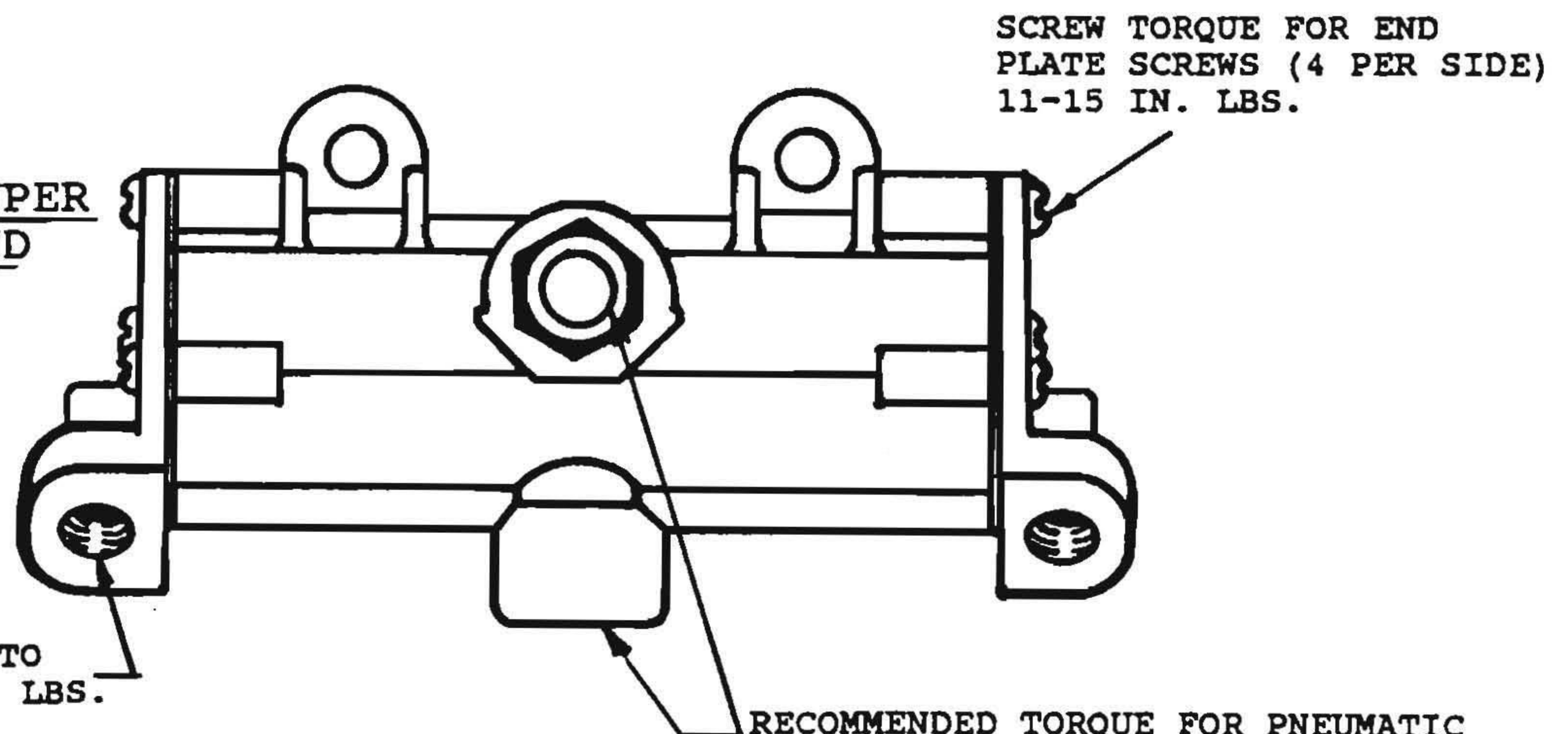

**PLEASE NOTE:**

THE METAL INSERTS FOR PNEUMATIC FITTING INSTALLATION ARE 1/8-27 N.P.S.F THREAD. WHEN FITTINGS ARE INSTALLED IN THESE INSERTS, USE LOCKTITE PIPE SEALANT W/TEFLON #59241 OR TEFLON PIPE SEALING TAPE OR EQUIVALENT TO A TORQUE OF 25-40 IN.LBS.

- \* ALL SERVICE MOTORS, REPAIR, RETURN AND UPDATE MOTORS AND SERVICE VALVES TO HAVE C-1044 TAG AFFIXED. ATTACHMENT MAY BE RUBBERBAND OR SECURED UNDER SCREW HEAD OR ANY OTHER APPLICABLE METHOD.

THE RESPONSIBILITY FOR CORRECT TORQUE OF FITTINGS AND SCREWS IS WHOLLY THAT OF THE CUSTOMER AND/OR REPAIR FACILITY.

\*

